

Introduction to Earth Science

Log on to YouTube and search for **jocrisci** channel. All videos listed with numbers below and sorted into playlists for easy access. Use these videos if you need extra practice or instruction.

Graphing (Video 1.2)

1. Look at a data table:
 - a. Determine which column contains the X data, and which contains the Y data
 - b. Calculate the correct scale to use for the X and Y axes
 - c. Plot the data
 - d. Connect the data points with a line
2. Look at a graph and explain which type of relationship it shows.
3. Look at a cyclic graph:
 - a. Calculate the length of a cycle
 - b. Label the maxima and minima
 - c. Using your calculated cycle length, make a prediction as to when the next maximum and minimum will occur.

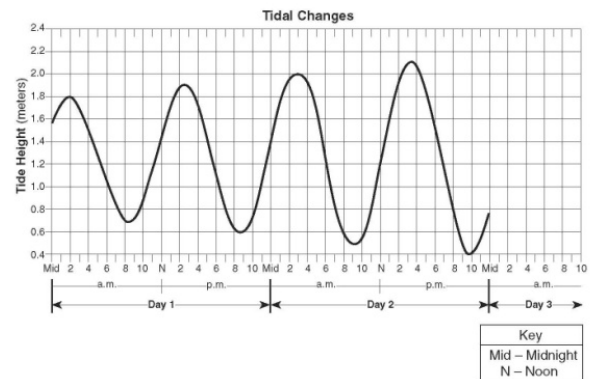

Formulas & Word Problems (Video 1.3 and ESRT 1b)

1. Look at a data table. Calculate the rate of change (using the formula in your reference tables), rounding your answer to the nearest tenth and including the correct units.
2. Find the density of the following:
 - a. A cube has a mass of 128 grams and a density of 2 g/cc. Find the length of one side.
 - b. A rectangle has a length of 5cm, a width of 4cm and a height of 2cm. It has a density of 3g/cc. Calculate its mass.
 - c. Using the graph to the right, find the density of objects A and B.

Introduction to Earth Science Facts

(Search Quizlet for username MsCWood – Introduction to Earth Science Facts)

1. Observation is / using your five senses to gather information
 2. Inference is / making an educated guess based on your observations
 3. Classification is / grouping of objects based on their characteristics
-
4. Direct relationship means / as one variable increases the other increases
 5. Inverse relationship means / as one variable increases the other decreases
 6. Constant relationship means / as one variable increases the other stays the same
 7. Cyclic relationship means / variables repeat and are predictable (ex. Moon Phases, Tides, and Seasons)
-
8. Density is / how close or compact the molecules are
 9. Density triangle / cover up the variable you want to solve for:
 10. The same objects have the / same density NO MATTER WHAT SIZE
-
11. As temperature increases / density decreases (molecules spread out) and volume increases (inverse relationship)
 12. Warm air or water rises because / it is less dense than cold air or water
 13. Cold air or water sinks because / it is more dense than warm air or water
 14. As pressure increases / density increases (molecules move closer together)
 15. Water has a density of / 1.0 g/cm^3 when it is still a liquid at 4°C
 16. For objects with densities less than 1, the lower it is / the higher it floats
 17. As water freezes it becomes / less dense (That is why ice floats)



Observation & Inferences

Observation: _____

Example(s): _____

Inference: _____

Example(s): _____

For each statement below, determine if it is an observation or an inference and explain your choice.

Statement	Circle One	Explain
1. The sample was transported by a glacier over 1 million years ago.	Observation Inference	
2. The sample is rectangular, with sharp, angular corners.	Observation Inference	
3. The water will become unsafe within 5 years.	Observation Inference	
4. Some of the snow on the glacier is powdery.	Observation Inference	
5. The sample is 8cm long, 5cm wide and 3cm high.	Observation Inference	
6. Hot and humid conditions will continue throughout the week.	Observation Inference	
7. There are many cracks in the glacier.	Observation Inference	
8. The sample is white in color.	Observation Inference	
9. A meteor impact caused the extinction of the dinosaurs.	Observation Inference	
10. The rock was transported by a stream.	Observation Inference	
11. The rocks in the glacier are different sizes.	Observation Inference	
12. Some parts of the glacier will start melting in the spring.	Observation Inference	

Observation & Inference Practice Questions

- Using a ruler to measure the length of a stick is an example of:
 - Extending the sense of sight by using an instrument
 - Calculating the percent error by using a proportion
 - Measuring the rate of change of the stick by making inferences
 - Predicting the length of the stick by guessing
- Which action can be performed most accurately using only the human senses?
 - Tearing a sheet of paper into squares whose sides measure 1 centimeter
 - Adding 10 grams of salt to a cup of water
 - Measuring the air pressure of a room
 - Counting 28 shells from a beach

- The map below shows the path of an ash cloud that results from the Mount St. Helens volcanic eruption. The map was developed from satellite photographs. The path of the ash cloud was most probably determined by:
 - Hypothesis
 - Inference
 - Observation
 - Theory

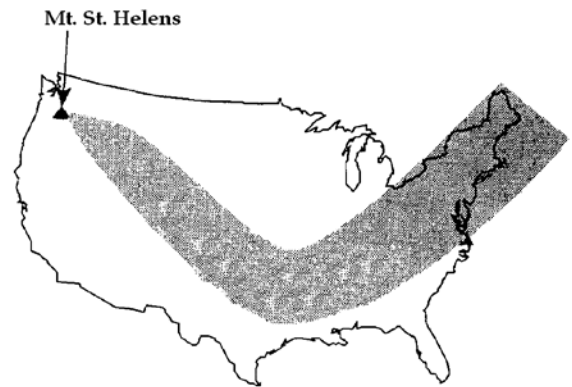

- An interpretation based upon an observation is called a(n):
 - Fact
 - Inference
 - Classification
 - Measurement
- While on a field trip to a large lake in New York State, an observer recorded four statements about this lake. Which of these statements is most likely an inference?
 - The lake was formed by glacial action
 - The water is clear enough to see the bottom of the lake.
 - A log is floating in the lake.
 - The surface temperature of the lake is 18.5°C.
- The grouping of objects or events based on similar characteristics is called:
 - Observation
 - Classification
 - Measurement
 - Interpretation
- A student classifies several objects. The classification system should be based on
 - Hypotheses
 - Inferences
 - Interpretations
 - Observations
- A prediction of next winter's weather is an example of:
 - Classification
 - Inferences
 - Measurement
 - Observations

Graphic Relationships

Facts to Memorize: 4-7

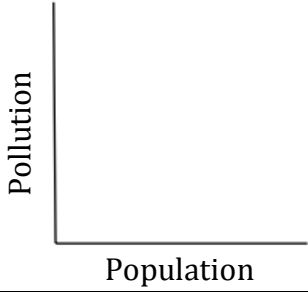
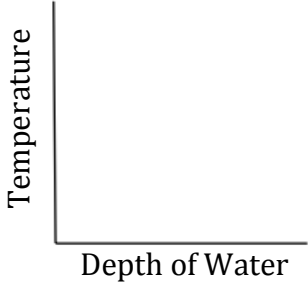
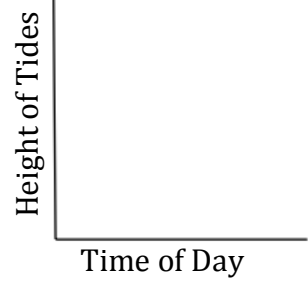
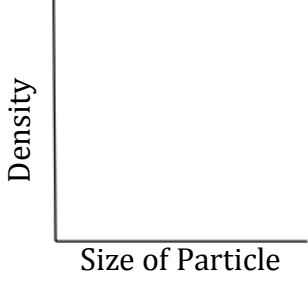
Graph	Statement	Examples
<p style="text-align: center;">DIRECT</p> 		
<p style="text-align: center;">INDIRECT</p> 		
<p style="text-align: center;">CYCLIC</p> 		
<p style="text-align: center;">NO RELATIONSHIP</p> 		

Graphic Relationships Practice

Fill in the missing information where appropriate.

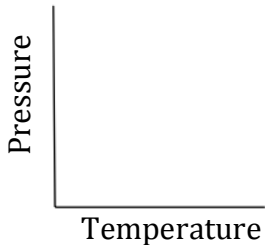
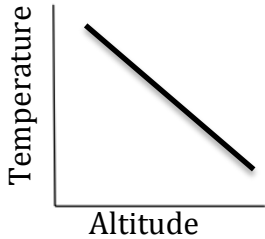
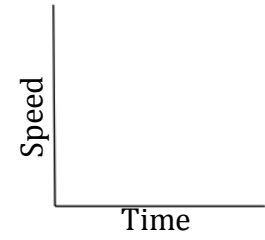
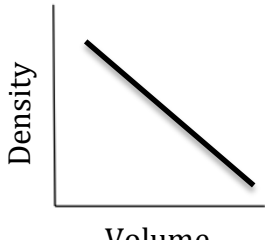
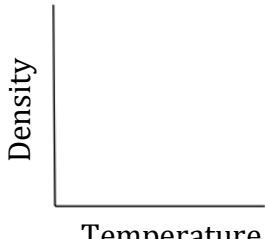
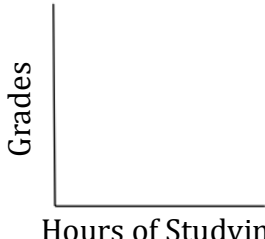
Type	Sketch	Graphic Statement
Direct		
		
		As time increases, speed remains the same.
		
Indirect		
		As the hours of studying increases, your grades increase.

Graphing Number of Ozone Molecules & Height

Height (mi)	Number of Ozone Molecules
8	20
18	40
25	60
42	80
58	100
82	105
101	127
105	152
116	230
119	248
128	250
138	240
156	180

You Must:

1. Create appropriate scales for both the X and Y axis
2. Label both the X and Y axis accordingly
3. Title the graph
4. Plot points from data table
5. Connect points with a line

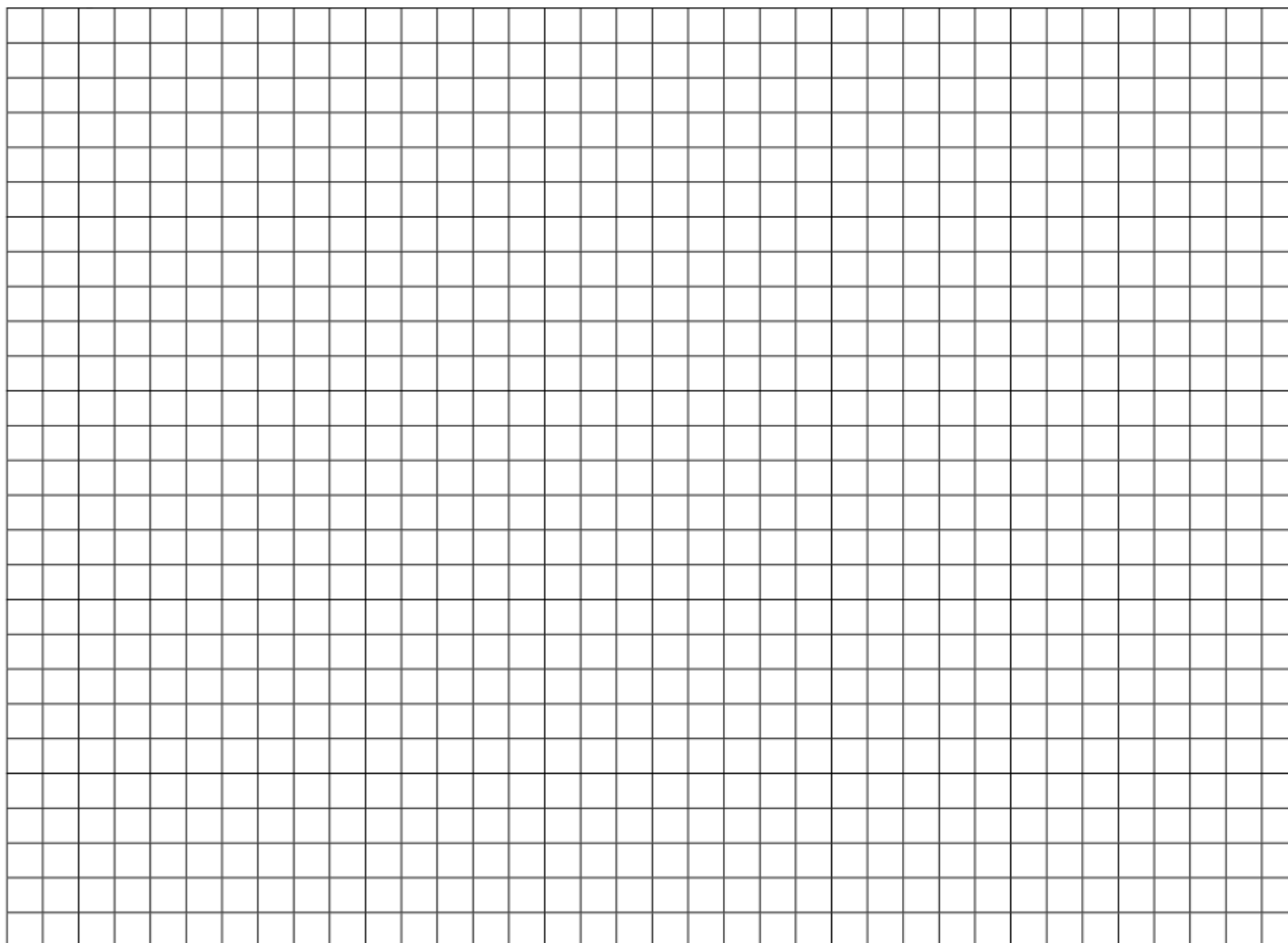

Earth Science Math Practice

Round the following numbers to the nearest tenth			
1) 5.77	_____	10) 0.98	_____
2) 13.74	_____	11) 1.02	_____
3) 0.667	_____	12) 7.984	_____
4) 77.37	_____	13) 8.253	_____
5) 829.25	_____	14) 18.96	_____
6) 513.8678	_____	15) 125.48	_____
7) 11.1723	_____	16) 0.956	_____
8) 9.97680	_____	17) 37.247	_____
9) 18.4835	_____	18) 1.5197	_____

Round the following numbers to the nearest thousandth	
19) 1.02548	_____
20) 10.92741	_____
21) 5.90182	_____
22) 32.41275	_____
23) 9.923109	_____
24) 0.08136	_____
25) 204.0001	_____
26) 8.9936	_____
27) 0.93167	_____

Subtracting Time

1. 10:09:50 <u>-10:08:25</u>	2. 9:45:10 <u>-9:25:10</u>	3. 3:15:33 <u>-3:14:43</u>	4. 7:22:55 <u>-7:21:55</u>
5. 4:15:57 <u>-4:14:30</u>	6. 1:24:43 <u>-1:22:05</u>	7. 2:05:17 <u>-1:55:34</u>	8. 8:17:05 <u>-7:30:05</u>
9. 6:57:32 <u>-5:58:33</u>	10. 8:17:28 <u>-7:45:36</u>	11. 12:59:59 <u>-11:04:21</u>	12. 5:02:03 <u>-4:59:59</u>

Rate of Change

Rate of Change: _____

Rate of Change Formula:

ESRT pg. 1

1. The temperature of water in a container was 60°C . Ten minutes later, the water temperature was 35°C . What was the rate of cooling of the water?

a. $25^{\circ}\text{C}/\text{min}$	c. $35^{\circ}\text{C}/\text{min}$
b. $2.5^{\circ}\text{C}/\text{min}$	d. $3.5^{\circ}\text{C}/\text{min}$

2. The graph shows the temperature readings for a day in April. The average rate of temperature change, in Fahrenheit degrees per hour, between 6 a.m. and noon was:

a. $6^{\circ}/\text{hr}$	c. $8^{\circ}/\text{hr}$
b. $3^{\circ}/\text{hr}$	d. $18^{\circ}/\text{hr}$

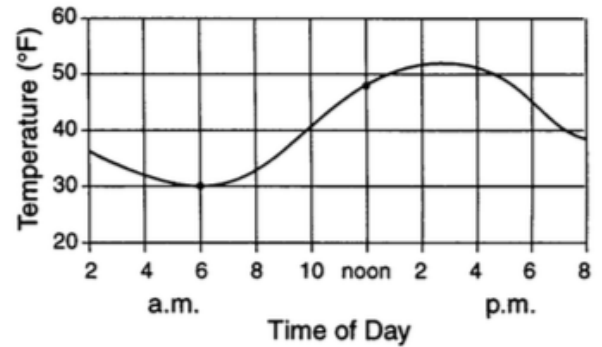

Use the graph to the right to answer questions 3 and 4. The graph represents the relationships between temperature and time as heat is added at a constant rate to equal masses of four substances labeled A, B, C, and D.

3. The temperature of which substance increased the most rapidly? _____
4. Which substance has a change that is not at a constant rate? _____
5. Calculate the average daily rate of movement of the hurricane during the period from 3 p.m. August 24 to 3 p.m. August 28. The hurricane traveled 2,600 kilometers during this 4-day period.

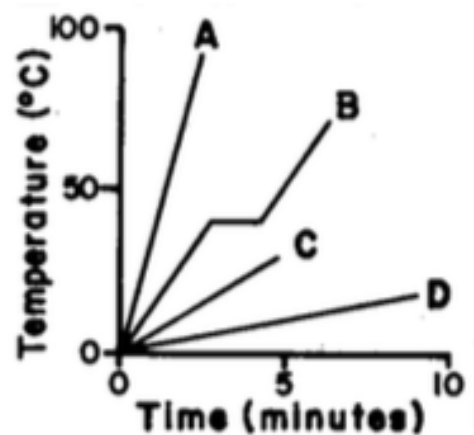

6. A student measures and records the temperature of water in a beaker for 8 minutes as shown below.

Time (min)	0	1	2	3	4	5	6	7	8
Temp. (C)	90	83	78	73	68	64	60	57	54

What is the average rate of cooling for the water in the beaker during the 8-minute time interval?

- a. 3.2 °C/min
 b. 3.6 °C/min
 c. 4.5 °C/min
 d. 4.0 °C/min
7. From 12 noon Thursday until 8 p.m. Thursday, the total amount of snowfall was 12 inches. Calculate the snowfall rate, in inches per hour.
- a. 0.67 in/hr
 b. 2.5 in/hr
 c. 3.5 in/hr
 d. 1.5 in/hr
8. Create a line graph using the following steps.
- Determine the correct scale that will best fit the data in the table below.
 - Title the graph and label the axis with units.
 - Plot the data and connect the points.

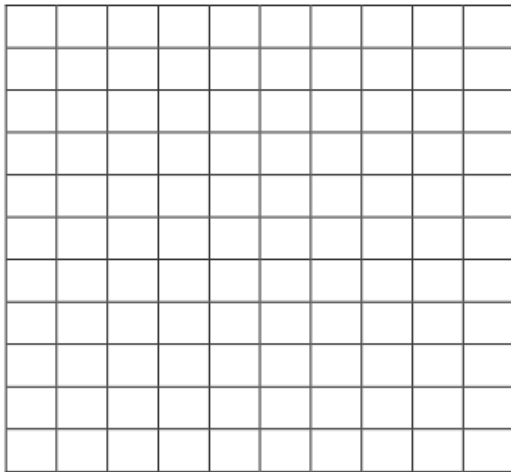

Time (min)	0	1	2	3	4	5	6	7	8	9	10
Temp. (C)	0	0	2	3	4	4	5	6	6	8	10

9. Determine the average rate of temperature change that occurred during this experiment.

10. By looking at the line graph, did the rate of temperature change **stay the same** throughout the experiment? _____

How do you know? _____

Density of Matter

Facts to Memorize: 8-10

Density: _____

Mass: _____

Volume: _____



Density Formula:

ESRT pg. 1

Example:



Mass = 162 g
Volume = 8.4 cm³

$$\text{Density} = \frac{\text{Mass}}{\text{Volume}} = \frac{\text{g}}{\text{cm}^3} = \text{g/cm}^3$$

If you take that sample of gold and break it into two exact halves, the mass and volume is half of the original, but the density REMAINS THE SAME.

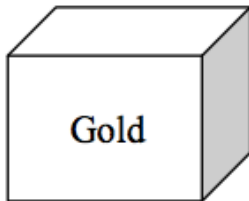
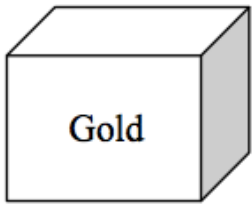



Mass = 81 g
Volume = 4.2 cm³

$$\text{Density} = \frac{\text{Mass}}{\text{Volume}} = \frac{\text{g}}{\text{cm}^3} = \text{g/cm}^3$$

Calculating Density Practice Questions:

1. If a wooden block were cut into eight identical pieces, the density of each piece compared to the density of the original block would be
 - a. Less
 - b. Greater
 - c. Equal
2. Under the same conditions of temperature and pressure, three different samples of the same uniform substance would have the same
 - a. Shape
 - b. Density
 - c. Mass
 - d. Volume

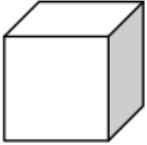
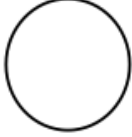
Base your answers to questions 3 through 6 on the diagrams below, which represent four **solid** objects made of the **same uniform material**. The volume of the sphere and the mass of the bar are not given.

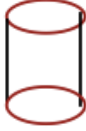
<p>Cube</p>  <p>Mass 81 g Volume 27 cm³</p>	<p>Sphere</p>  <p>Mass 75 g Volume ?</p>	<p>Bar</p>  <p>Mass ? Volume 30 cm³</p>	<p>Cylinder</p>  <p>Mass 60 g Volume 20 cm³</p>
--	--	---	--

3. What is the density of the bar?
 a. 9.9 g/cm³ b. 3.0 g/cm³ c. 30.0 g/cm³ d. 90 g/cm³
4. Which graph best represents the relative densities of the objects?

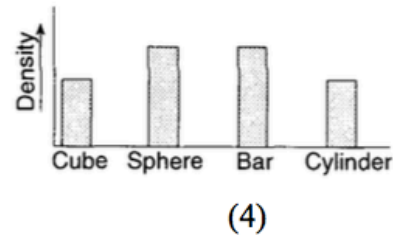
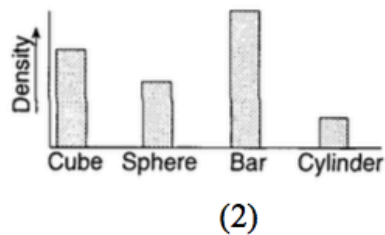
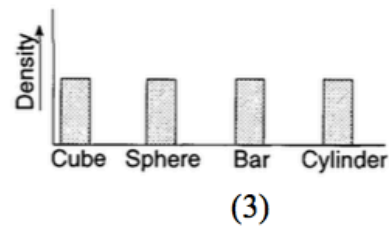
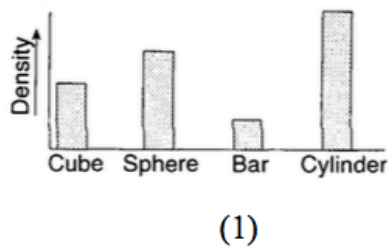

5. What is the mass for the bar?
 a. 90 g b. 10 g c. 30 g d. 3 g
6. What is the volume for the sphere?
 a. 5 cm³ b. 15 cm³ c. 25 cm³ d. 35 cm³
7. An unknown sample has a density of 6 g/cm³. If the sample were cut in half, each half would have a density of:
 a. 12 g/cm³ b. 9 g/cm³ c. 3 g/cm³ d. 6 g/cm³
8. The original sample A is cut into several pieces. When compared with the density of the original sample, the density of each piece will be:
 a. Less b. Greater c. The same

Changes in Density

Two factors that effect density are _____ and _____

TEMPERATURE: As temperature increases, the mass remains the same and molecules begin to expand (move apart) which means the volume increases.

Example:

$$\text{Density} = \frac{\text{Mass}}{\text{Volume}} = \frac{10 \text{ g}}{2 \text{ cm}^3} = 5 \text{ g/cm}^3$$

$$\text{Density} = \frac{\text{Mass}}{\text{Volume}} = \frac{10 \text{ g}}{10 \text{ cm}^3} = 1 \text{ g/cm}^3$$

Note: As volume increases, density _____.

Draw the Graphic Relationship between Temperature and Density.

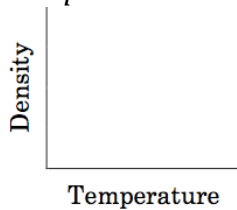

As temperature increases, density _____.

What type of graphic relationship does density and temperature have?

Phases of Matter

- Most Earth materials have their greatest density as a _____
 - EXCEPT for WATER because solid water (ice) _____ in liquid water.
- Water is at its **greatest** density at a temperature of _____ C.

ESRT pg. 1
- The density of water is _____ g/ml
- If an object floats on water, it is _____ dense than water. (*Values less than 1*)
- If an object sinks in water, it is _____ dense than water. (*Values greater than 1*)

PRESSURE: As pressure increases, the mass remains the same and molecules are compressed (move closer together) which means the volume decreases.

Example:

$$\text{Density} = \frac{\text{Mass}}{\text{Volume}} = \frac{10 \text{ g}}{10 \text{ cm}^3} = 1 \text{ g/cm}^3$$

$$\text{Density} = \frac{\text{Mass}}{\text{Volume}} = \frac{10 \text{ g}}{2 \text{ cm}^3} = 5 \text{ g/cm}^3$$

Note: As volume decreases, density _____.

Draw the Graphic Relationship between Pressure and Density.

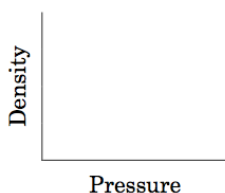

As pressure increases, density _____.

What type of graphic relationship does density and pressure have?

Density Relationships Practice Questions:

Base your answers to questions on 1 and 3 on the diagram below. Object A is a solid cube of uniform material having a mass of 65 grams and a volume of 25 cubic centimeters. Cube B is a part of cube A.

- The density of the material in cube A is determined at different temperatures and phases of matter. At which temperature and in which phase of matter would the density of cube A most likely be greatest?
 - 20°C and in the solid phase
 - 1200°C and in the liquid phase
 - 1800 °C and in the liquid phase
 - 2700°C and in the gaseous phase

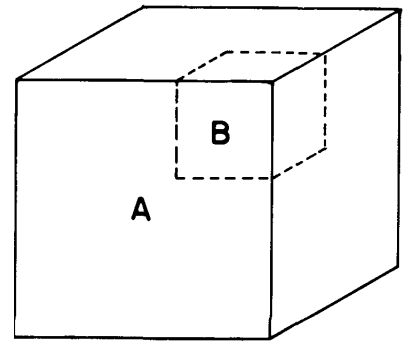

- If cube B is removed from cube A, the density of the remaining part of cube A will:
 - Decrease
 - Increase
 - Remain the same
- The mass of cube B is measured in order to calculate its density. The cube has water on it while its mass is being measured. How would the calculated value for density compare with the actual density?
 - The calculated density value would be less than the actual density.
 - The calculated density value would be greater than the actual density.
 - The calculated density value would be the same as the actual density.

Base your answers to questions 4 through 6 on the diagram below, which represents a solid material of uniform composition.

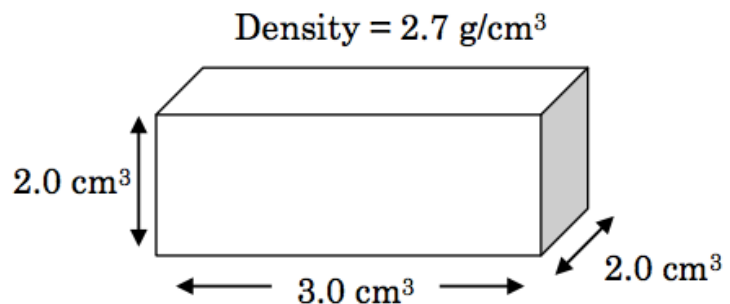

- What is the mass of the material?
 - 18.9 g
 - 4.5 g
 - 32.4 g
 - 40 g
- If this material is heated and expands, the density of the material will:
 - Decrease
 - Remain the same
 - Increase
- Which graph best represents the relationship between the mass and volume of various- sized pieces of this material?

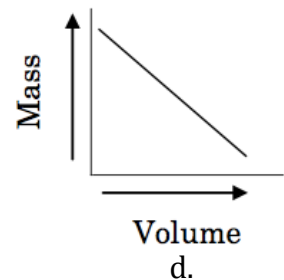
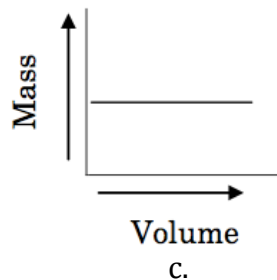
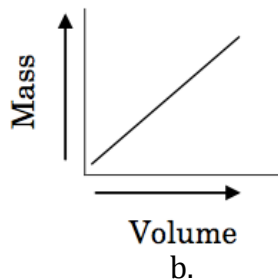
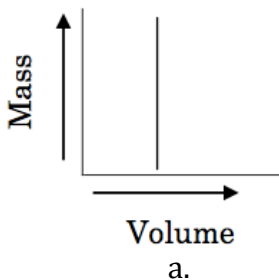

7. As water cools from 4°C to 0°C, its density:
- a. Decreases b. Increases c. Remains the same
8. As the volume of air expands due to heating, the density of this air will:
- a. Decreases b. Increases c. Remain the same
9. Water has the greatest density at approximately:
- a. 100°C in the gaseous phase c. 0°C in the solid phase
- b. 4°C in the solid phase d. 4°C in the liquid phase

10. A student measured the mass and volume of the mineral crystal to the right and recorded the data shown below. The student used these data to calculate the density of the crystal. What is the density according to the student's data?

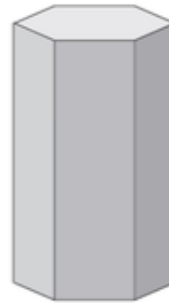

Data	
Mass =	80 g
Volume =	32 cm ³
Density =	?

- a. 1.0 g/cm³
- b. 1.5 g/cm³
- c. 2.0 g/cm³
- d. 2.5 g/cm³
11. The diagram to the right represents a cylinder, which contains four different liquids, W, X, Y, and Z, each with a different density (D) as indicated. A piece of solid quartz having a density of 2.7 g/cm³ is placed on the surface of liquid W. Which the quartz is released, it will pass through:
- a. W, but not X, Y, or Z
- b. W and X but not Y, or Z
- c. W, X, and Y, but not Z
- d. W, X, Y, and Z

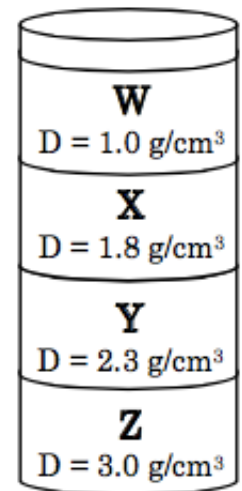

12. Which graph best represents the relationship between the density of a substance and its state of matter (phase) for most earth materials, excluding water?

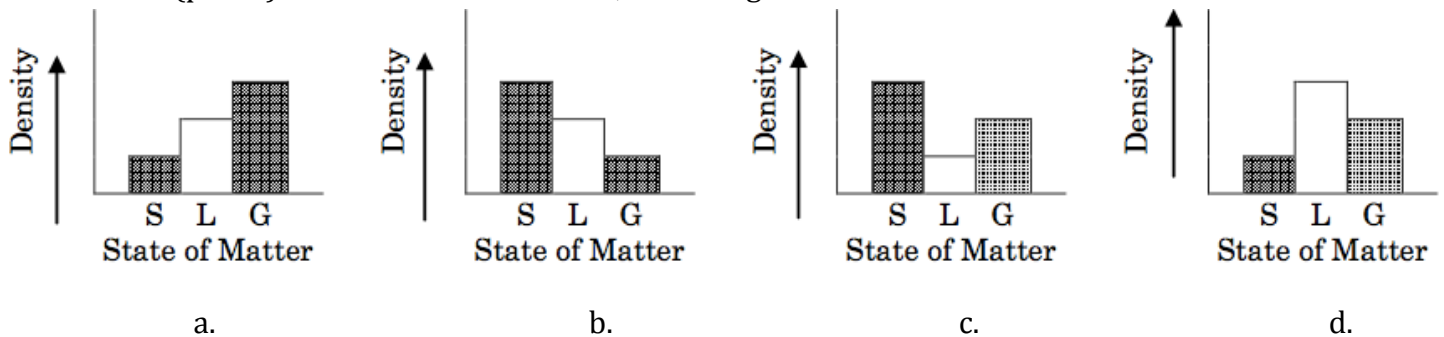

Base your answers to questions 13-19 on the information below. Each sample is made of the same uniform material. YOU MUST SHOW ALL WORK (Formula, plug-in & answer with units).

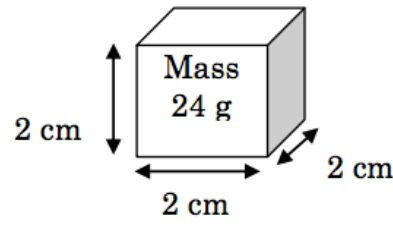
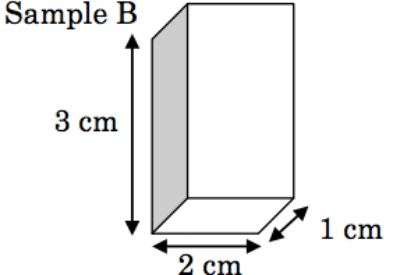
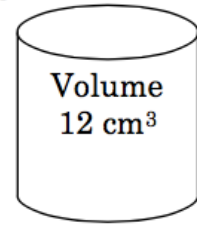
<p>Sample A</p>  <p>Mass 24 g</p>	<p>Sample B</p>  <p>3 cm</p> <p>2 cm</p> <p>1 cm</p>	<p>Sample C</p>  <p>Volume 12 cm³</p>
---	--	--

13. Determine the volume of Sample A.

14. Determine the volume of Sample B.

15. What is the density of Sample A?

16. What is the mass of Sample B?

17. What is the mass of Sample C?

18. Fill in the chart to the right with the data you calculated above.

Sample:	A	B	C
Mass (g)			
Volume (cm ³)			

19. Draw a graph below that represents the density of these three samples.

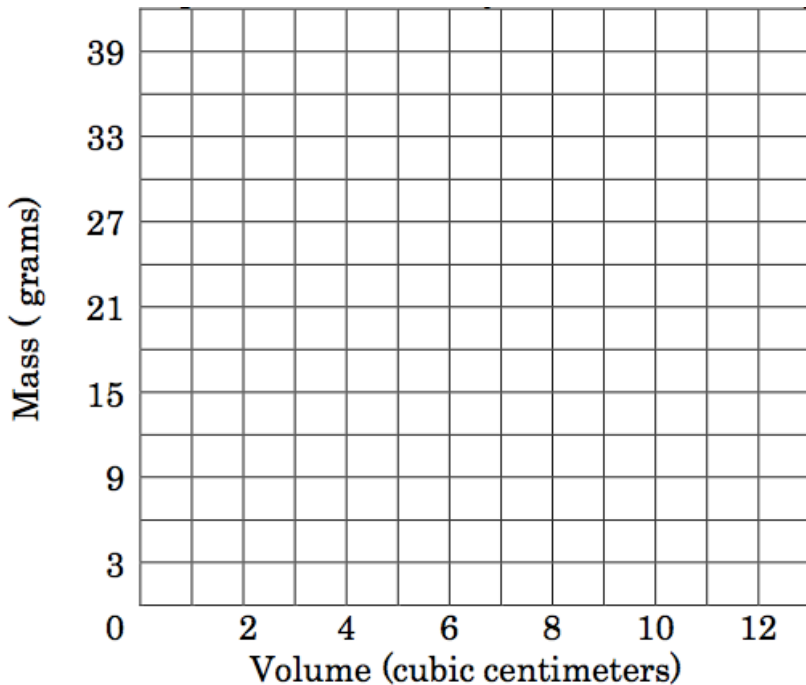

Base your answers to questions 20 and 21 on the data table below. The data table below shows the mass and volume of three sample of the same mineral.

20. Determine the density of each of the samples below.

Sample	Mass (g)	Volume (cm ³)	Density (g/cm ³)
A	50	25	
B	100	50	
C	150	75	

21. Which graph best represents the relationship between density and volume of these mineral samples?

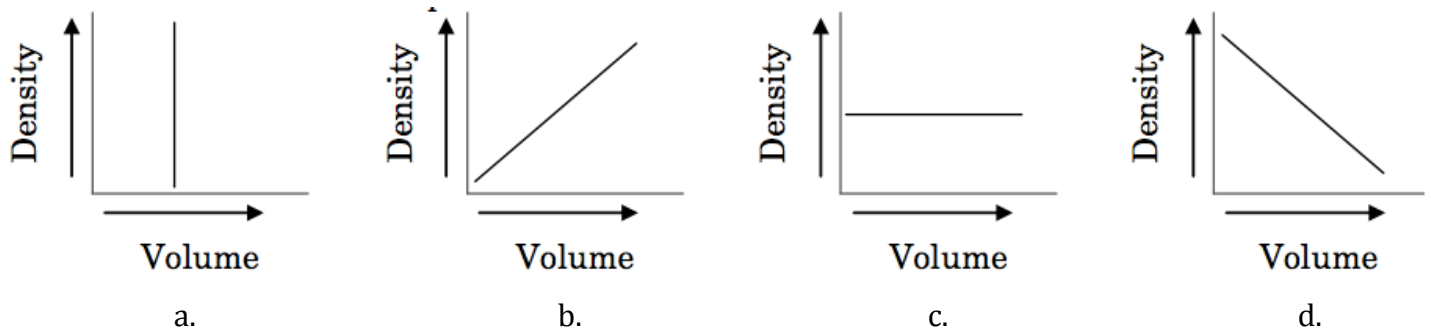

Base your answers to questions 22-24 on the graph below which shows the relationship between mass and volume for three materials X, Y and Z which are all at equal temperatures.

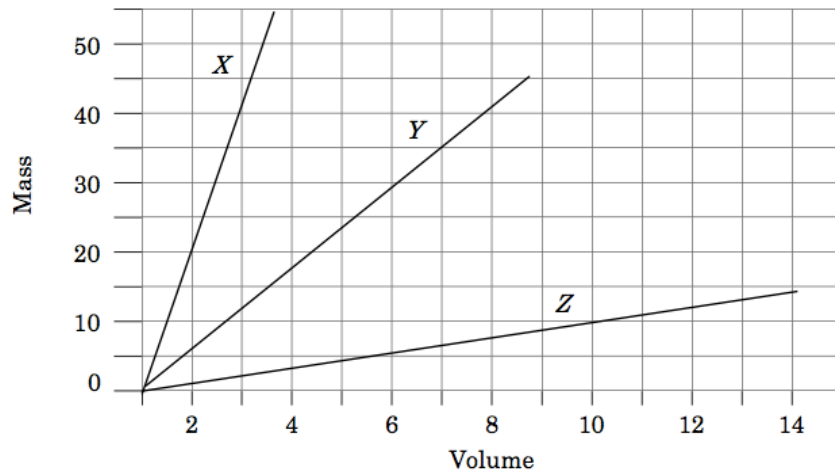

18. What is the approximate density of material Y?

- a. 1.0 g/cm³ b. 0.2 g/cm³ c. 5.0 g/cm³ d. 10.0 g/cm³

19. When the volume of material Z is 14 cm³, its mass is:

- a. 8 g b. 10 g c. 14 g d. 16 g

20. Using the graph above, draw a line graph for a material that has a volume of 7 cm³ and a mass of 12 g.

Introduction to Earth Science Review Questions

1. A student breaks a glass beaker in class. What should you do?
a) Pick up the broken pieces b) get the teacher
c) Ignore it d) throw out the broken pieces
2. In which phase (state) does water have their greatest density?
a) Gaseous b) liquid c) solid
3. Organizing information in a meaningful way is an example of:
a) Prediction c) Classification
b) Measurement d) Observation
4. Which one of the following is an inference?
a) Roses are red b) the candle wick is burning
c) Apple pie is sweet d) the dinosaur bone is old
5. A measurement is best defined as:
a) An inference made by using the human senses
b) Direct comparison to a known standard
c) An interpretation based on theory
d) A group of inferred properties
6. A number of objects grouped based on similar properties is called:
a) Inference b) Observation c) Prediction d) Classification
7. As amount of sunlight increases, the temperature increases. What graphic relationship is represented?
a) Direct b) Indirect c) Cyclic d) Constant
8. In which phase (state) do *most* Earth materials have their greatest density?
a) Gaseous b) liquid c) solid
9. As time of day increases, the tide height changes in a repeating, predictable pattern. What graphic relationship is represented?
a) Direct b) Indirect c) Cyclic d) Constant
10. Ocean tides are best described as:
a) predictable and noncyclic
b) predictable and cyclic
c) unpredictable and cyclic
d) unpredictable and noncyclic

11. If pressure is applied to a rock until its volume is reduced by one half, how does its new density compare to its original density?
- a) It is half its original density
 - b) It is twice its original density
 - c) It is the same as its original density
 - d) It is one-third its original density
12. A golden bar has a density of 2.0g/cm^3 . If the bar is cut into 4 pieces, what is the density of each of the pieces?
- a) 4.0g/cm^3
 - b) 2.0g/cm^3
 - c) 0.5g/cm^3
 - d) 0.25g/cm^3

*For the following questions – Show ALL work
(Formula, plug in, answer rounded to the nearest tenth with units!)*

13. The wooden block has a mass of 10g and a volume of 14cm^3 . Calculate the density.
14. The television has a density of 125gcm^3 with a volume of 25cm^3 , what is the mass of the television?
15. The textbook has a mass of 32g and a density of 76gcm^3 , what is the volume of the textbook?
16. A hot air balloon rose from a height of 100m to 400m in 3 minutes. What was the balloons rate of change?
17. A missile flies 20miles in 10 minutes. Calculate the missile's rate of change.
18. A glacier advanced down a mountain from an elevation of 2010m to 1780m in 5 years. What was the glaciers rate of change?
19. A student's grade goes from a 95 to a 60 in 3 weeks because they didn't do their homework. Calculate the student's grade rate of change.